



# TOGO

SCONCES OUTDOOR

ADA  
COMPLIANT  
location:  
**WET**

## SPECIFICATIONS:

### DESCRIPTION

The captivating Togo wall luminaire showcases a half oval design, expertly crafted from skillfully blown glass. This luminaire's beauty lies in its molded glass diffuser, which is carefully hand-decorated with an opaque bronze or black finish, exuding sophistication and style. The warm smoke tint adds a touch of warmth to the light, creating a cozy and inviting atmosphere.

### LAMPING

**Standard:** 75W A19 120V, lamps not included.

**LED Filament:** 7W Replaceable Filament A19 lamp, 120V, dimmable, 80+ CRI, 3000°K CCT, 800 lumens, 15,000 hours, lamp included.

### DIFFUSER

Glass diffuser is molded glass in Black or Bronze finish, with a warm Smoke tint. Dimensions are 5.25" W x 9.5" H x 4" D.

### CONSTRUCTION

Stamped Stainless steel fitter. Glass is secured by stainless steel set screws.

### MOUNTING

Installs directly to a 4" octagonal outlet box, centered on fixture. 75°C supply wire required for incandescent lamping.

### LABELS

UL or ETL Listed. Suitable for Wet Locations. May be used in Interior or Exterior applications.

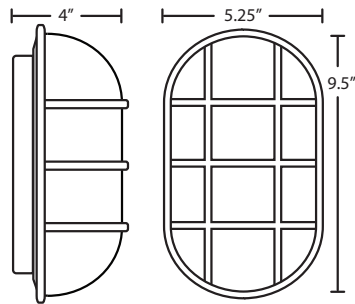

## ORDERING:

FIXTURE	- LAMP OPTIONS -	FINISH
TOGO Togo	(blank) 75W A19 EDIL 7W LED	BK Black/Smoke BR Bronze/Smoke

**Ex. TOGO-BK**  
Togo Sconce w/ Smoke Bubble,  
Black Finish

### Project Information:

All dimensions provided are nominal. Allowance must be made for dimensional tolerance in handcrafted glasses.

REV 7/23