



BES0000-012

120V PENDANT

location:
DAMP

SPECIFICATIONS:

DESCRIPTION

Chain-hung pendant with Drum in Linda Cream Fabric.

LAMPING

CFL: 4x 32W CFL 277V, non-dimming, lamp not included.

DIFFUSER

Linda Cream Fabric with top Clear acrylic and bottom Frost acrylic.
24" Dia. x 12" H

SUSPENSION

Chain-hung: 5' Chain section, includes Gold Cord, secured to a 5" Dia. Canopy. Black finish.

MOUNTING

Installs directly to a 4" octagonal ceiling box. Suitable for sloped ceilings.

LABELS

UL or ETL Listed. Suitable for Damp Locations (interior use only).
Consult factory concerning lower wattage labeling for energy requirements.

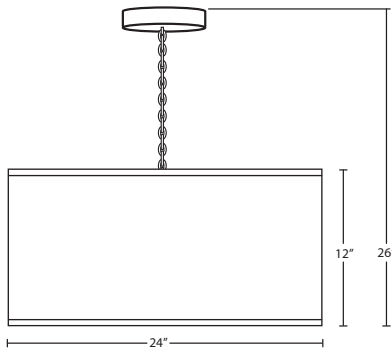

ORDERING:

BES0000-012

Chain-hung pendant, Linda Cream Fabric Drum, 4x 32W CFL, 277V

Part Number

Description

Project Information:

All dimensions provided are nominal.
Allowance must be made for dimensional tolerance in handcrafted glasses.